

# HN OSG-R

## Oil Level Sight-Glass

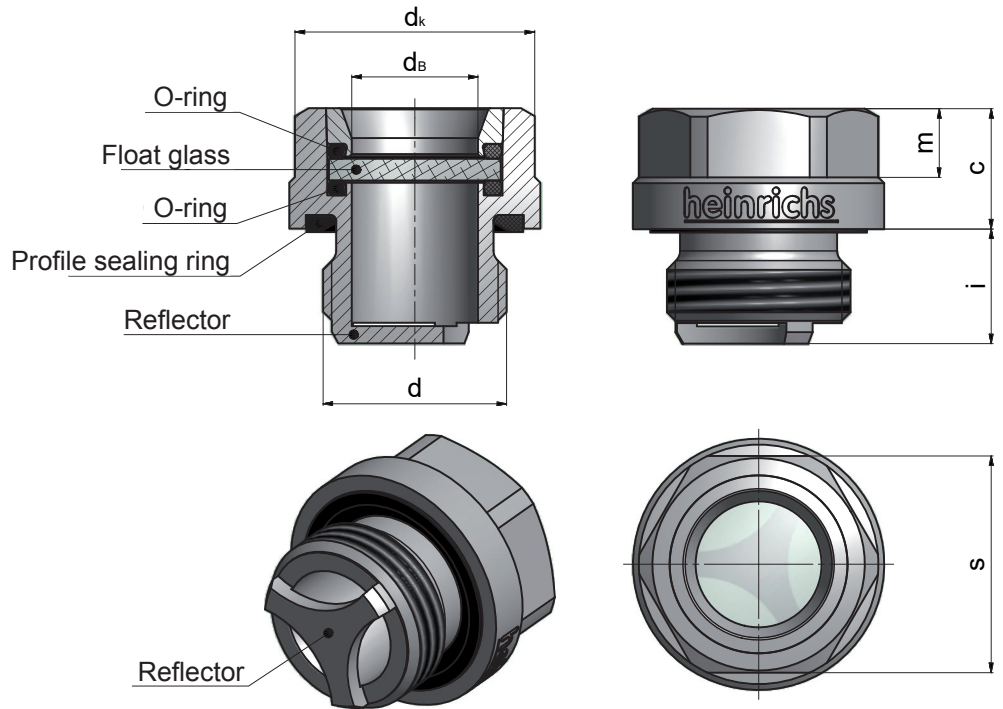

### Application areas:

- Gearbox components
- ATEX compliant version upon request
- Designed for an operating pressure between -0,05 MPa (-0,5 bar) and 0,3 MPa (3 bar)
- Appropriate for a temperature range of -30°C until +90°C
- For counter bores as per DIN 3852-2 and EN ISO 9974-1
- Can be loosend and tightend repeatedly

### Material:

- Steel 11SMnPb30+C (1.0718)  
DIN EN 10227-3 ultrasonic and crack tested or "HD-quality"
- Stainless steel 1.4305 / 1.4571
- Other materials upon request

### Coating:

- Cr-(VI) free: nano passivated  
A3K/Zn Nano (ISO 4042)
- Other coatings upon request

### Special features:

- The sealing of the glass plate is done with two high elastic o-rings, which also cushion effectively the sight glass against pressure surges and vibrations
- The reflector and the basic body are one unit and thus not detachable!

d		c	dk	dB	i	m	s	Tightening torque	Weight
Metric fine thread	Pipe threads								
DIN 13	DIN EN ISO 228	±0,3	h14	±0,3	±0,2	±0,2	h14	Nm*	~kg per 100 pieces
M10 x 1	G 1/8 A	9,5	14	7	8	6	13	8	0,78
M12 x 1,5	—	10,5	17	8	10	6	15	14	1,37
M14 x 1,5	G 1/4 A	10,5	18,8	8	10	6	16	16	1,90
M16 x 1,5	G 3/8 A	10,5	21,9	11	10	6	19	30	2,45
M22 x 1,5	G 1/2 A	12,5	27	14	12	7	24	45	4,80
M27 x 2	G 3/4 A	14	32	18	14	8	30	70	8,10
M33 x 2	G 1 A	14,5	39	24	14	8	36	100	10,90
M42 x 2	G 1 1/4 A	15	49	31	14	9	46	160	18,50

\* Recommendation for counter threads made of untempered steel. Its reaction depends on the material, coating and quality and must be verified by the customer in each specific application case!