

HN8-WD

Sealing plug

with elastic seal

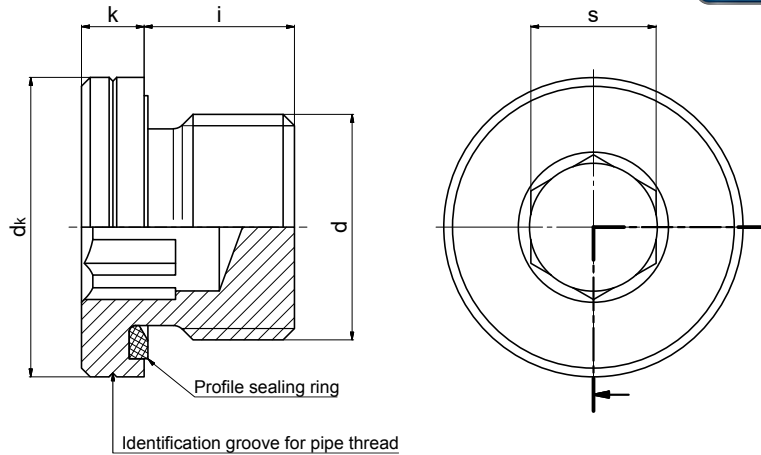

Application areas:

- Engineering, gear manufacturing, automotive and many others
- for counter bores as per DIN 3852-2 and EN ISO 9974-1
- can be undone and screwed in repeatedly

Profile sealing ring acc. DIN 3869:

- NBR 85 Shore -30°C to +100°C (-22°F to +212°F)
- FKM 80 Shore -20°C to +200°C (-4°F to +392°F)
- other temperature ranges upon request

Material:

- Steel 11SMnPb30+C (1.0718) DIN EN 10227-3 ultrasonic and crack tested or "HD-quality"
- Stainless steel 1.4305 / 1.4571
- other materials upon request

Coating:

- Cr-(V) free: nano passivated A3K/Zn Nano (ISO 4042)
- ZNNI as per VDA 235.104-25
- other coatings upon request

d		k	dk****	i	s	Tightening torque	Operating pressure	Weight
Metric fine thread	Pipe thread	±0,3	h14	±0,2	D12	Nm*	MPa (1 MPa = 10 bar)	~kg per 100 pieces
DIN 13	DIN EN ISO 228							
M8 x 1	—	4	12	8	4	8	40 MPa	0,50
M8 x 1,25**	—	4	12	8	3	8	40 MPa	0,50
M10 x 1	G 1/8 A	4	14	8	5	12	40 MPa	0,68
M10 x 1,5**	—	4	14	8	4	12	40 MPa	0,68
M12 x 1**	—	5	17	12	6	25	40 MPa	1,33
M12 x 1,5	—	5	17	12	6	25	40 MPa	1,33
—	G 1/4 A	5	18,9	12	6	30	40 MPa	1,82
M14 x 1,5	—	5	19	12	6	35	40 MPa	1,90
M16 x 1,5	—	5	21,9	12	8	50	40 MPa	2,20
—	G 3/8 A	5	22	12	8	55	40 MPa	2,63
M18 x 1,5	—	5	23,9	12	8	60	40 MPa	3,13
M20 x 1,5	—	5	25,9	14	10	70	40 MPa	4,02
—	G 1/2 A	5	26,9	14	10	80	40 MPa	4,43
M22 x 1,5	—	5	27	14	10	80	40 MPa	5,00
M24 x 1,5	G 5/8 A	5	29,9	14	12	95	40 MPa	5,80
M26 x 1,5	—	5	31,9	16	12	120	40 MPa	7,52
—	M27 x 2	5	32	16	12	135	40 MPa	7,65
M28 x 1,25**	—	6,5	36,9	16	12	155	40 MPa	11,10
M30 x 1,5	M30 x 2	6,5	36,9	16	17	190	40 MPa	10,80
M33 x 1,5	M33 x 2	6,5	39,9	16	17	225	40 MPa	12,60
M42 x 1,5	M42 x 2	6,5	49,9	16	22	360	25 MPa	20,00
M42 x 1,5	M42 x 2	8	49,9	20	22	360	40 MPa	26,00
M48 x 1,5	M48 x 2	6,5	55	16	24	400	25 MPa	25,00
M48 x 1,5	M48 x 2	8	55	22	24	400	40 MPa	33,00
—	G 2 A	8	68	20	24	650	25 MPa	53,00

* Recommendation for counter threads made of untempered steel. Its reaction depends on their material, coating and quality and must be verified by the customer in case of each specific application!

** Not a common dimension but deliverable!

*** Screw plugs can be stamped with manufacturer's sign "hd" on the front face and screw plugs made of stainless steel can be additionally stamped with the material marking "A4"!

**** Values that exceed the outer diameter „dk“ due to feed scoring and/or surface coating by up to 0.1 mm are acceptable.