

# HN8-OR

Sealing plug  
with internal hexagon and o-ring

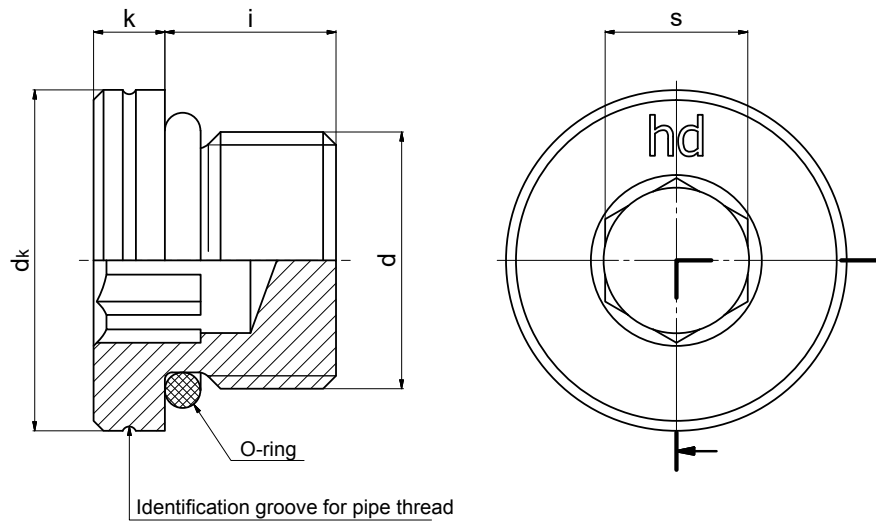

### Application areas:

- Hydraulics
- For counterbores as per DIN 6149-1
- Can be loosened and tightened repeatedly

### O-ring acc. DIN 3601:

- NBR 90 Shore -30°C to +100°C (-22 F to +212 F)
- FKM 90 Shore -20°C to +200°C (-4 F to +392 F)
- Other temperature ranges upon request

### Material:

- Steel 11SMnPb30+C (1.0718)  
DIN EN 10227-3, ultrasonic and crack tested, or "HD-quality"
- Stainless steel 1.4305 / 1.4571
- Other materials upon request

### Coating:

- Cr-(VI) free: nano passivated A3K/Zn Nano (ISO 4042)
- ZNNI as per VDA 235.104-25
- Other coatings upon request

d		k	dk	i	s	Tightening torque	Operating pressure	Weight
Metric fine thread								
DIN 13		-0,25	±0,2	±0,2	D12	Nm*	MPa*** (1 MPa = 10 bar)	~kg per 100 pieces
M8 x 1	—	3,5	11,8	9,5	4	8	40	0,50
M10 x 1	—	3,5	13,8	9,5	5	15	53,2	0,70
M12 x 1,5	—	4	16,8	11	6	22	63	1,09
M14 x 1,5	—	4	18,8	11	6	45	63	1,50
M16 x 1,5	—	4	21,8	12,5	8	55	63	2,18
M18 x 1,5	—	4,5	23,8	14	8	70	63	3,82
M22 x 1,5	—	4,5	26,8	15	10	100	63	4,90
M26 x 1,5	—	4,5	31,8	16	12	150	40	7,19
—	M27 x 2	4,5	31,8	18,5	12	170	40	8,24
—	M30 x 2	5	35,8	18,5	17	215	40	10,00
—	M33 x 2	5,5	39,8	18,5	17	310	40	12,90
—	M42 x 2	5,5	49,8	19	22	330	25	21,25
—	M48 x 2	5,5	54,8	21,5	22	420	25	33,34

\* Recommendation for counter threads made of untempered steel. Its reaction depends on the material, coating and quality and must be verified by the customer in each specific application case!

\*\* Screw plugs made of stainless steel can be stamped additionally with a material mark on the front face.

\*\*\* Recommendation for a maximum operating pressure under industry-standard conditions. As the behaviour depends on certain facts such as pressure increase rate, number of cycles, temperature, viscosity and mating thread strength, it must be verified by the customer if operating circumstances are exceptionally tough. We are able to support our customers, if needed.